

**Mäder Aero**

*Part of Socomore Group*

# ADVANCED AEROSPACE COATINGS SOLUTIONS



**socomore** *The Surface Company*



# Aerospace and Spec

## MÄDER AERO makes the difference



### HIGH TECHNICAL SOLUTIONS

- Anti corrosion chromate free solutions
- Erosion Preventive Coatings
- High temperature resistant coatings
- (Ultra)conductive Coatings



### GLOBAL SERVICE

- Agility and flexibility to meet perfectly your needs
- Co-development products and processes together with our customers
- Custom made products and solutions for a large range of equipment

SOCOMORE : +45 YEARS  
EXPERIENCE IN AEROSPACE

WE SATISFY THE MOST  
STRINGENT SPECIFICATIONS

# ial Coatings Systems

with agility and sustainable innovation



## ADVANCED ECO-FRIENDLY SOLUTIONS

- Waterborne coatings
- High Solid content coatings
- Reach compliant solutions
- Chromate free coatings



## INTERNATIONAL PRESENCE

- 5 plants worldwide
- 22 subsidiaries & sales offices

**WE ARE A GLOBAL PARTNER**

**11% EMPLOYEES IN R&D**

# PRODUCTS AND SERVICES: OUR AEROSPACE SOLUTIONS

## PRODUCT TYPES

We can engineer all types of paint systems:

- Chromate free waterborne and high solid primers
- Decorative and UV resistant top coats
- Special coatings: anti-erosion, anti-corrosion, conductive primers, heat resistance...

Our products are REACH compliant:

- Waterborne and high solid V.O.C compliant products
- Chromate free products - no chrome VI and no chrome III



## SERVICES

Mäder Aero is supporting you worldwide

- Worldwide availability and technical support thanks to Socomore subsidiaries and our distribution network

## MAIN CERTIFICATIONS, QUALIFICATIONS & CONSORTIUMS

Mäder is certified according to the major European ISO standards:

- EN 9100 & ISO 9001 for Aerospace Quality Management System
- ISO 14001 regarding environmental issues

Most of our products are qualified by the most prestigious OEM's such as:

- Airbus Group
- Collins Aerospace
- Liebherr Aerospace
- Safran Group
- Thales

Mäder Aero is part of several Aerospace Associations & Consortiums

- GIFAS: the French aerospace industries association
- IRT M2P
- GICAT

## APPLICATIONS



### BLADES, RADOMES & FANS

#### Rain & Sand erosion issues

- Waterborne and High solid system primer & top coat
- Conductive version
- Repair Kit available

**Main OEM qualifications:**  
Airbus Group - Safran Group - Collins Aerospace

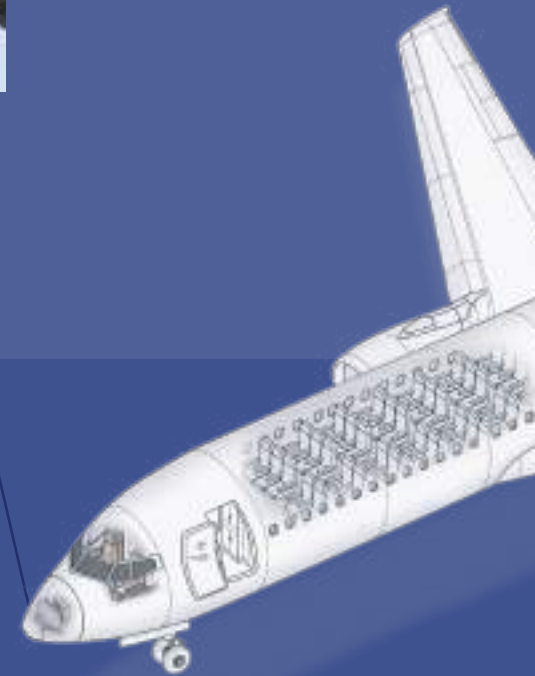

### ENGINE & NACELLES

#### Corrosion & High Temperature issues

- High solid UV resistant PU top coat for nacelles
- Chromate free anti-corrosion coating with a heat resistance for engine shaft
- Anti-erosion system for fan blades and OGV blades

**Main OEM qualifications:**  
Safran Group - LEAP Program





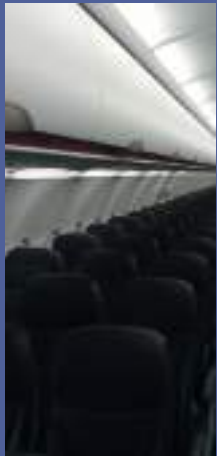

## INTERIOR CABINS

### Decorative, durability & flammability issues

- Backlighting paint for cockpit
- Custom made colors
- Fire resistance paint



## SPECIAL COATINGS

### Various equipment & related issues

- Waterborne and chromate free conductive primers (anti-static)
- Lightning protection epoxy coating for composite parts
- Anti-corrosion varnish with a heat resistance for Heat exchangers

**Main OEM qualifications:** SECAN - Liebherr Aerospace



## BOOSTERS AND SPACE ROCKETS

### Corrosion, heat and conductivity issues

Rocket nozzles

### **Main OEM qualifications:**

Ariane Group  
MT Aerospace



## LANDING GEARS, WHEELS and BRAKING SYSTEMS

### Corrosion, fretting & High Temperature issues

- Chromate free primers - high solid & waterborne
- Anti-corrosion and heat resistance paint for torque tubes

### **Main OEM qualifications:**

Safran Group - Honeywell

# Mäder Aero

Part of Socomore Group

## ADVANCED ECO-FRIENDLY FUNCTIONALIZED COATINGS SOLUTIONS

EXPERT IN INNOVATIVE SOLUTIONS WITH HIGH TECHNOLOGICAL CONTENT  
TO BETTER PRESERVE THE ENVIRONMENT AND HUMAN BEING



### ADVANCED ECO-FRIENDLY SOLUTIONS

- Green technologies & products
- Health and Safety of human well-being
- ISO 14001 certified production sites
  - Continued involvement for a sustainable and responsible development



### SERVICE & INTERNATIONAL PRESENCE

- International dimension close to our customers
  - Fulfilling local needs
  - Technical assistance
  - Customer training
- Tailor-made developments



### HIGH TECH SOLUTIONS

- Specialized R&D task force
  - 3 laboratories worldwide
- Partnerships with universities and research centers
- High-Tech and innovative solutions : water-based paints, chromate free solutions





# BLADES, RADOMES & FANS ENVIRONMENT

## Rain and sand erosion issues

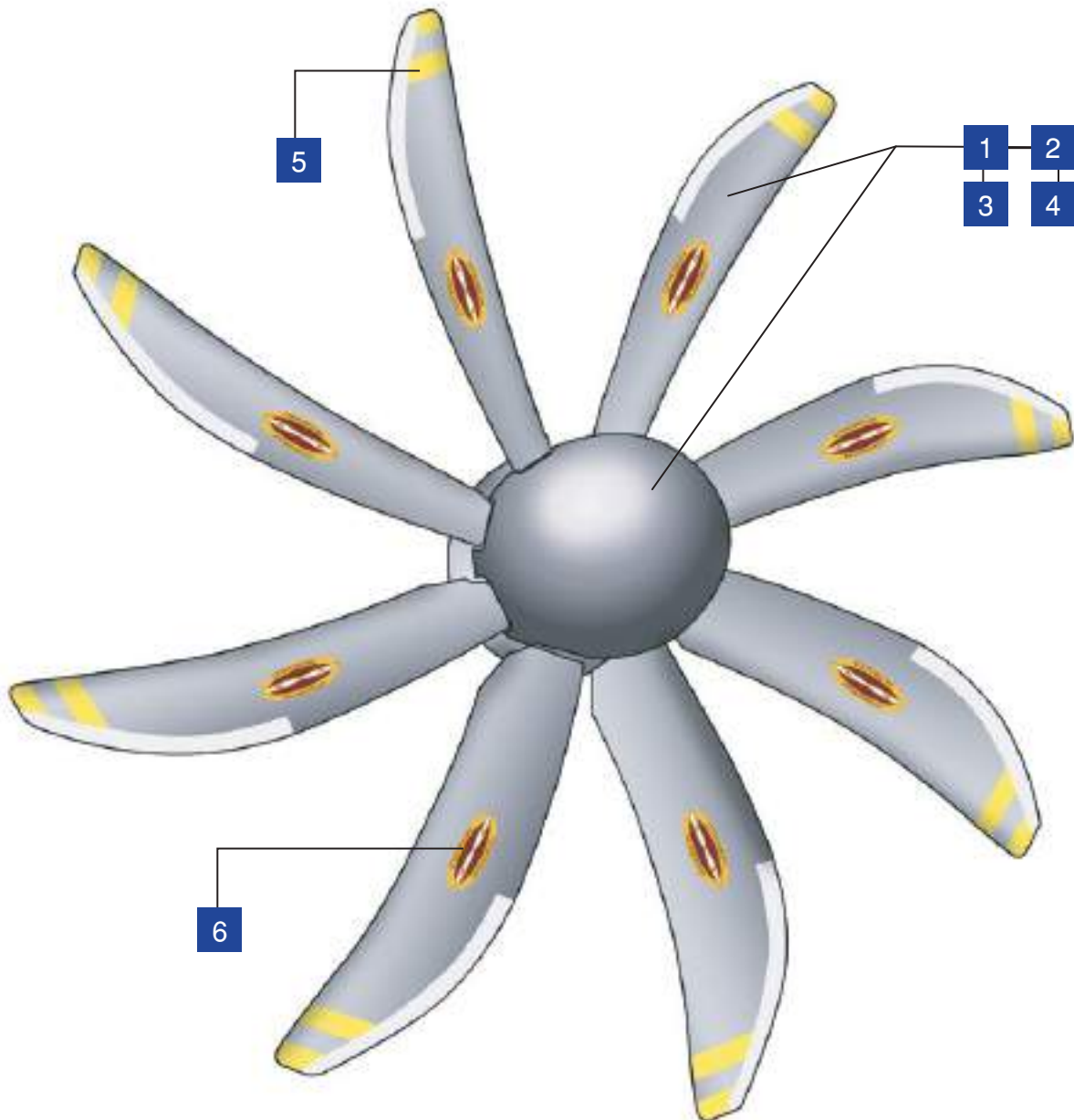



#	Reference	Product Type	Chemical	Colour	Product Properties	Areas of use	Main specifications
<b>BLADES, RADOMES &amp; FANS ENVIRONMENT</b>							
1	ARTEWASH 12	Chromate free wash primer	Polyvinyl Butyral	Red	Anticorrosion protection, adhesion promotor.	On every metallic parts prior epoxy or polyurethane primer	DMR74-500A
2	D2339	Chromate free primer	Epoxy, solventborne	Grey, Beige	Anticorrosion protection, excellent adhesion properties	Aluminium and composite substrate: blades, spinner cone	
2	PCEH 100	Chromate free primer	Epoxy, waterborne	Beige - can be adapted upon request	High solid, chromate free, waterborne primer. Anticorrosion & excellent adhesion CAA/SAA/BSAA	Aluminium and composite substrate: blades, spinner cone	ECSO100 DMR74-072C
2	SOCOGLAZE PRIMER WB413	Chromate free primer	Epoxy, waterborne	Beige - can be adapted upon request	High solid, chromate free, waterborne primer. Anticorrosion & excellent adhesion CAA/SAA/BSAA	Aluminium and composite substrate: blades, spinner cone	ECSO100
2	SOCOGLAZE PRIMER WB421	Chromate free primer	Epoxy, waterborne	Beige - can be adapted upon request	High solid, chromate free, waterborne primer. Anticorrosion & excellent adhesion CAA/SAA/BSAA	Aluminium and composite substrate: blades, spinner cone	FN131-2
3	LEH 640	Chromate free primer	Epoxy, waterborne	Beige - can be adapted upon request	High solid, chromate free, waterborne primer. Anticorrosion, anti-fretting & skydrol resistance	Aluminium and composite substrate: blades, spinner cone	FN131-1 IFC 30-125-05 HS7136
4	PRIAM 35375 Cond	Anti erosion conductive top coat	Solventborne, polyurethane	Any colour matte	Rain & sand erosion resistance.	Any substrate exposed to sand & rain erosion issues: radome, blades, spinner cone	840/AIACP/ 6120/99
4	LBYH 203 V2	Waterborne anti erosion top coat	Waterborne, polyurethane	Any colour matte	Rain & sand erosion resistance. UV & anti-stone resistance	Any substrate exposed to sand & rain erosion issues: radome, blades, spinner cone	DMR74-071D
4	LBYH 205 Black Cond	Anti erosion conductive top coat	Waterborne, polyurethane	Matte Black	Rain & sand erosion resistance. Anti-static version	Any substrate exposed to sand & rain erosion issues: radome, blades, spinner cone	FN131-2
4	SOCOGLAZE EPC WB541	Anti erosion conductive top coat	Waterborne, polyurethane	Any colour matte	Rain & sand erosion resistance. UV & anti-stone resistance	Any substrate exposed to sand & rain erosion issues: radome, blades, spinner cone	ECSO101
5	LBYH 150	Top coat	Waterborne, polyurethane	Any colour	From Ultramatte to High Gloss, good resistance to UV, weather and chemicals	Security marking, decoration, protection.	
5	HYDROTHANE 61	Top coat	Waterborne, polyurethane	Any colour	Decorative Coating, high gloss retention, UV resistant, flexible and low density paint system	Security marking, decoration, protection.	HS7136
6	LBYH 150 Clearcoat	Clear coat	Waterborne, polyurethane	Clear	Clear varnish, good resistance to UV, weather and chemicals	Protection	





# INTERIOR CABIN & FUSELAGE

Decorative, durability and flammability issues

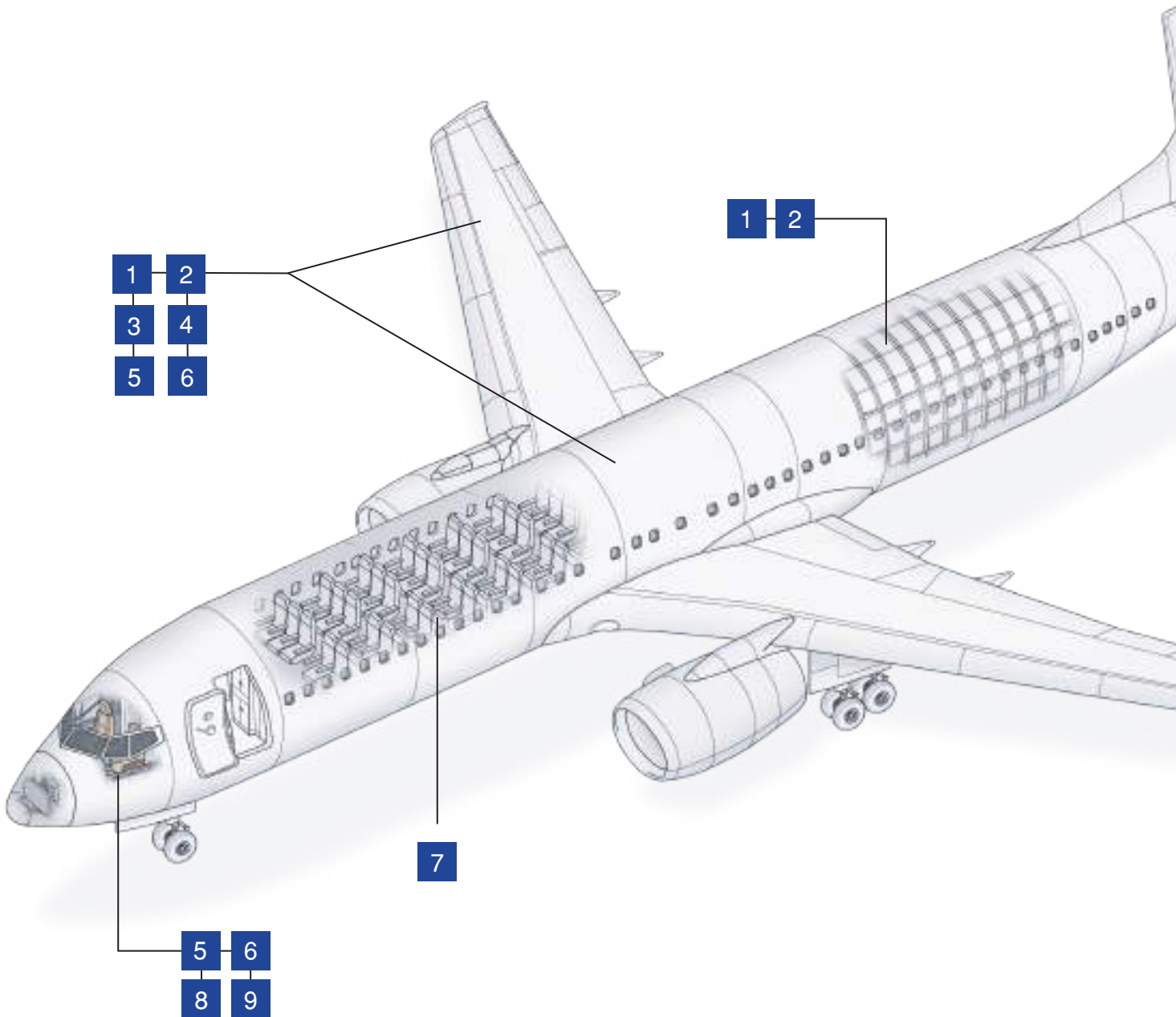

#	Reference	Product Type	Chemical	Colour	Product Properties	Areas of use	Main specifications
<b>FUSELAGE &amp; EXTERNAL EQUIPEMENT</b>							
1	ARTEWASH 12	Chromate free washprimer	Polyvinyl Butyral	Red	First level of anticorrosion protection, adhesion promotor, chromate free	On every metallic parts prior epoxy or polyurethane primer.	DMR74-500A
2	NUVOVERN FR	Chromate free and Fire Resistant Pore Filler	Epoxy	Blue Grey	Bi-component epoxy pore filler for spatula application. Fast Dry, easy to sand.	Composite parts	61921083-024C
3	PCEH 100	Chromate free washprimer	Waterborne, epoxy	Light Yellow/Black	High solid, chromate free, waterborne primer. Anticorrosion & excellent adhesion CAA/SAA/BSAA	Aluminium and composite substrate: blades, spinner cone, areas not exposed to skydrol	ECS0100 DMR74-072C
3	PCEH 201	Chromate free primer	Waterborne, epoxy	Grey	High solid, chromate free, waterborne primer. Anticorrosion & excellent adhesion CAA/SAA/BSAA	Aluminium and composite substrate: areas not exposed to skydrol	61921083-024C
3	SOCOGLAZE PRIMER WB410	Chromate free primer	Waterborne, epoxy	Grey	High solid, chromate free, waterborne primer. Anticorrosion & excellent adhesion CAA/SAA/BSAA	Aluminium and composite substrate: areas not exposed to skydrol	
3	SOCOGLAZE PRIMER WB411	Chromate free primer	Waterborne, epoxy	Beige	High solid, chromate free, waterborne primer. Anticorrosion, anti-fretting & skydrol resistance	Aluminium and composite substrate	
3	LEH 640	Chromate free washprimer	Waterborne, epoxy	Light sand	High solid, chromate free, waterborne primer. Anticorrosion, anti-fretting & skydrol resistance	Aluminium and composite substrate: blades, spinner cone	FN131-1 IFC 30-125-05 HS7136
4	MADERCOAT HES 540	High solid polyurethane top coat	Polyurethane	Any colour	High Solid PU top coat, high flexibility, UV resistant, high gloss	Final top coat for parts and external schemes	
5	D146/246/346	Solventborne external top coat	Polyurethane	Any colour	High gloss retention (mat, semi-gloss, gloss), UV resistant	For external schemes and dashboard	16 262 048 - 024 IP 29123 527-2
5	LBYH 150	Top coat	Waterborne, polyurethane	Any colour	From Ultramatte to High Gloss, good resistance to UV, weather and chemicals	Security marking, decoration, protection.	16 262 669-024
<b>INTERIOR CABIN &amp; COCKPIT EQUIPMENT</b>							
5	D146/246/346	Solventborne external top coat	Polyurethane	Any colour	High gloss retention (mat, semi-gloss, gloss), UV resistant	For external schemes and dashboard	16 262 048 - 024 IP 29123 527-2
5	LBYH 150	Top coat	Waterborne, polyurethane	Any colour	From Ultramatte to High Gloss, good resistance to UV, weather and chemicals	Security marking, decoration, protection.	16 262 669-024
6	LUMIFLOR RSA 22039	Specialty top coat for backlighting system	Polyurethane	White	LUMIFLOR is applied on dashboard, buttons, swiches as a top coat or as undercoat, recovered by a top coat angraved by laser or machined	Dashboards and buttons of aircrafts, submarines, cars, etc	
7	SOCOGLAZE EPC WB541	Waterborne anti erosion top coat	Waterborne, polyurethane	Any colour Matte	Pass fire testing. Resistant to abrasion and soft feel.	Any substrate exposed to abrasion.	ECS0101
8	SOMALAC CP211	Soft feel matte black top coat	Polyurethane	Matte Black	Soft touch, smooth matte black	Controls and cockpit elements	LORD 322284D2 Taxiing control of A320
9	VARNISH TD20	Clear varnish	Epoxy	Clear	Insulating varnish	Electronic purposes	Z.12.401





# ENGINE ENVIRONMENT

Corrosion, Erosion and high temperature issues





#	Reference	Product Type	Chemical	Colour	Product Properties	Areas of use	Main specifications
<b>NACELLE</b>							
1	LBYH 142	UV resistant top coat	Polyurethane, waterborne	Any colour	Very good resistance to UV	Every composite parts exposed to UV	HMRC0089 MDL 5050
<b>HIGH TEMPERATURE RESISTANT COATINGS FOR ENGINES</b>							
2	MADERBIND CF	Sacrificial, aluminium based primer, chromate free and corrosion resistance	Sacrificial inorganic and waterborne	Metallic Grey	High temperature (up to 450°C) and corrosion resistance. Available in both 1k or 2k versions.	Every steel parts exposed to high temperature and corrosion: engine shaft	DMR74-510
3	SOCOGLAZE SPC 8061	High temperature resistance coating	Silane	Aluminium	High temperature (up to 600°C) and corrosion resistance	Every steel parts exposed to high temperature and corrosion	
4	BOLICONE K Aluminium	High temperature resistance coating	Silicon	Aluminium	High temperature (up to 600°C) and corrosion resistance	Every steel parts exposed to high temperature and corrosion	DMP 16-009
4	BOLICONE M4	High temperature resistance coating	Silicon	Aluminium	High temperature (up to 600°C) and corrosion resistance	Every steel parts exposed to high temperature and corrosion	DMR 74-026 DMR 74-067 DGQT 0.4.2.0323
<b>FAN BLADES, COMPOSITE AND OGV BLADES</b>							
5	PRIAM CE 211	Epoxy primer	Epoxy	Glossy grey	Adherence promotor & metallic parts protection	Aluminium substrate : spinner cone	DMR74-035
5	PRIAM CE 111	Epoxy primer	Epoxy	Glossy grey	Adherence promotor & composite protection	Composite structural parts composite turbine blades engine's environment	DMR74-051 138/aéro/61 16 261 974 - 024
5	PCEH 100	Chromate free primer	Epoxy waterborne	Beige	High solid, chromate free, waterborne primer. Anticorrosion & excellent adhesion CAA/ SAA/ BSAA	Any substrate exposed to sand & rain erosion issues: radome, blades, spinner cone	DMR74-035
5	PCEH 100 V2	Chromate free primer	Epoxy waterborne	Beige	High solid, chromate free, waterborne primer. Anticorrosion & excellent adhesion CAA/ SAA/ BSAA	Aluminium and composite substrate : blades, spinner cone	DMR74-072D
6	PRIAM 32005	Anti erosion top coat	Polyurethane	Any colour	Erosion protection	Any substrate exposed to sand & rain erosion issues: radome, blades	DMP 16-030 DMR74-035 DMR74-051 SM 78026-B 16 261 974 - 024 Inst. 42 199 674/AIACP/ 6120/99
7	LBYH 203 V2	Waterborne anti erosion top coat	Polyurethane waterborne	Black	Rain & sand erosion resistance. UV and anti-stone resistance	Any substrate exposed to sand & rain erosion issues: radome, blades, spinner cone	DMR74-071
8	LBYH 205 Black Cond.	Waterborne anti erosion top coat: updated & improved version	Polyurethane waterborne	Black	High performance for rain erosion resistance	Any substrate exposed to sand & rain erosion issues: radome, blades, spinner cone	FN131-2





# SPECIAL COATINGS

## Various equipment & related issues

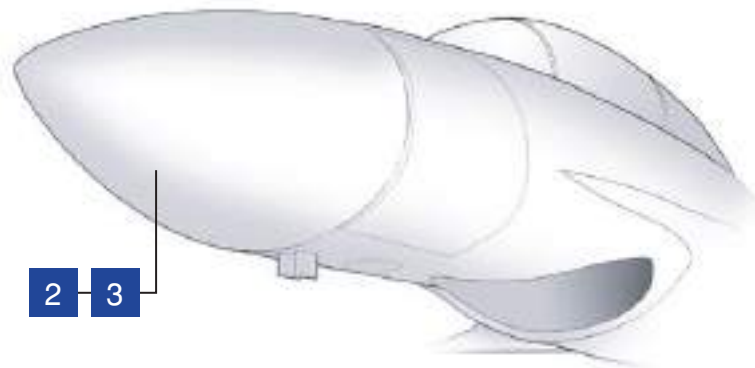
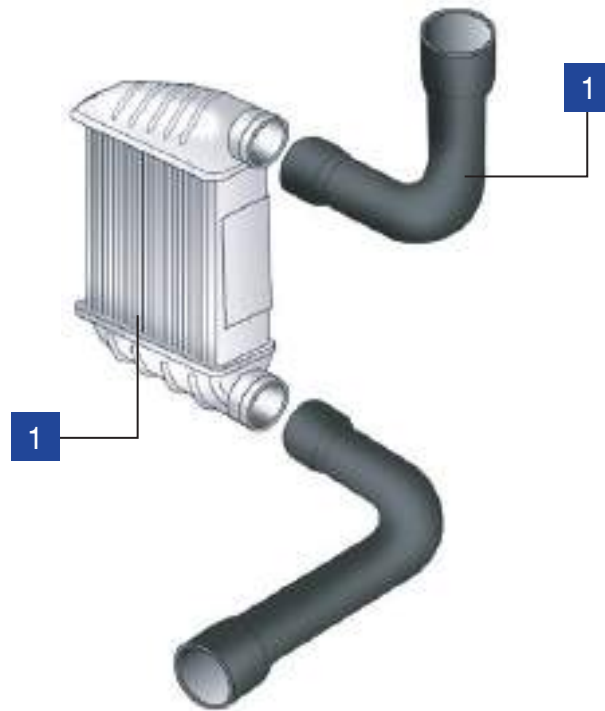

#	Reference	Product Type	Chemical	Colour	Product Properties	Areas of use	Main specifications
<b>HEAT EXCHANGER</b>							
1	LFPH 006 VARNISH	Anti-corrosion and Heat resistance varnish	Waterborne Epoxy-phenolic	Clear varnish	Heat resistance and corrosion protection. Dipping allowed.	Heating systems, heat exchangers...	DTP/06-0318/CR 1-TS-P-028 / FTP-11-8412-12-3
1	LFPH 006	Anti-corrosion and Heat resistance varnish	Waterborne Epoxy-phenolic	Aluminium, Black, Grey, Gold	Heat resistance and corrosion protection.	Heating systems, heat exchangers...	DTP/06-0318/CR 1-TS-P-028 / FTP-11-8412-12-3
<b>RADOME</b>							
2	PRIAM CE 111	Epoxy primer	Epoxy	Glossy grey	Adherence promotor & composite protection	Composite structural parts composite turbine blades engine's environment	DMR74-051 138/aéro/61 16 261 974 - 024
3	PRIAM 32005	Anti erosion top coat	Polyurethane	Any colour	Erosion protection	Any substrate exposed to erosion issues : radome, blades	DMP 16-030 DMR74-035 DMR74-051 SM 78026-B 16 261 974 - 024 Inst. 42 199 674/AIACP/6120 /99
3	BOLICOAT	Anti erosion top coat	Polyurethane	Any colour	Erosion protection	Any substrate exposed to erosion issues : radome, blades	585/AIACP/6120 /00





# LANDING GEARS, WHEELS & BRAKING SYSTEMS

Corrosion, fretting and high temperature issues

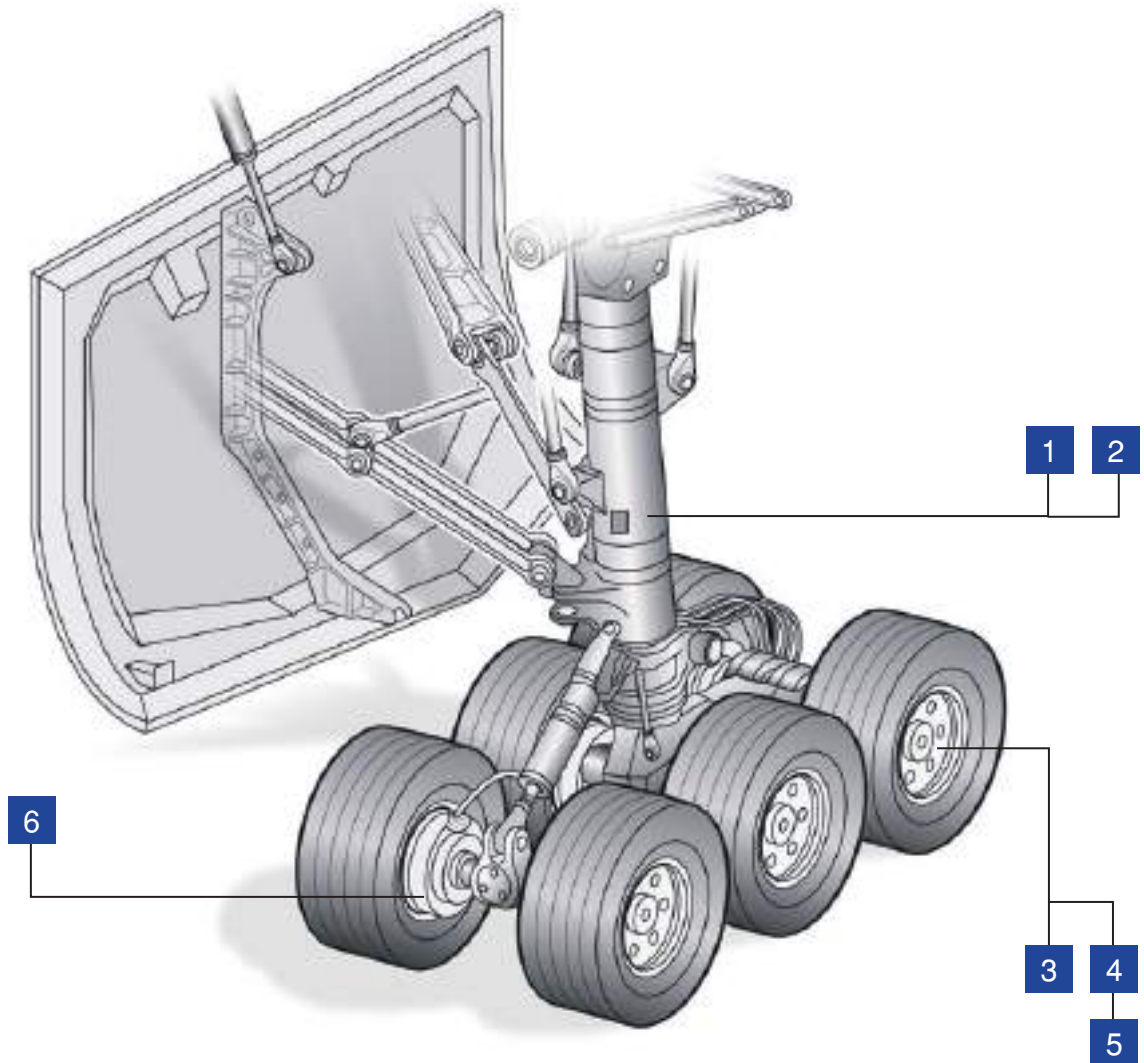



#	Reference	Product Type	Chemical	Colour	Product Properties	Areas of use	Main specifications
<b>LANDING GEARS</b>							
1	LEH 640	Chromate free primer	Epoxy, waterborne	Light yellow	High solid, chromate free, waterborne primer. Anticorrosion, anti-fretting & skydrol resistance	Wheels, every aerospace parts.	IFC 30-125-05
2	MADERCOAT HES 540	High solid polyurethane top coat	Polyurethane	Any colour	High solid PU Top Coat, high flexibility, UV resistant, high gloss retention	Final top coat for parts and external schemes.	
<b>WHEELS</b>							
3	LEH 640	Chromate free primer	Epoxy, waterborne	Light yellow	High solid, chromate free, waterborne primer. Anticorrosion, anti-fretting & skydrol resistance	Wheels, every aerospace parts.	IFC 30-125-05
4	MADERCOAT HES 540	High solid polyurethane top coat	Polyurethane	Any colour	High solid PU Top Coat, high flexibility, UV resistant, high gloss retention	Final top coat for parts and external schemes.	
5	D146/246/346	Top coat	Polyurethane	Any colour	High gloss retention (matte, semi-gloss, gloss), UV resistant	For external schemes.	
<b>TORQUE TUBE</b>							
6	LFSH 066	High temperature resistant coating	Organic modified, waterborne	Black	Corrosion & High temperature resistance (up to 600°C)	Every steel parts exposed to high temperature - Torque tubes	32-09-01 section 61A





# SPACE ROCKETS & BOOSTERS

## Corrosion, heat and conductivity issues

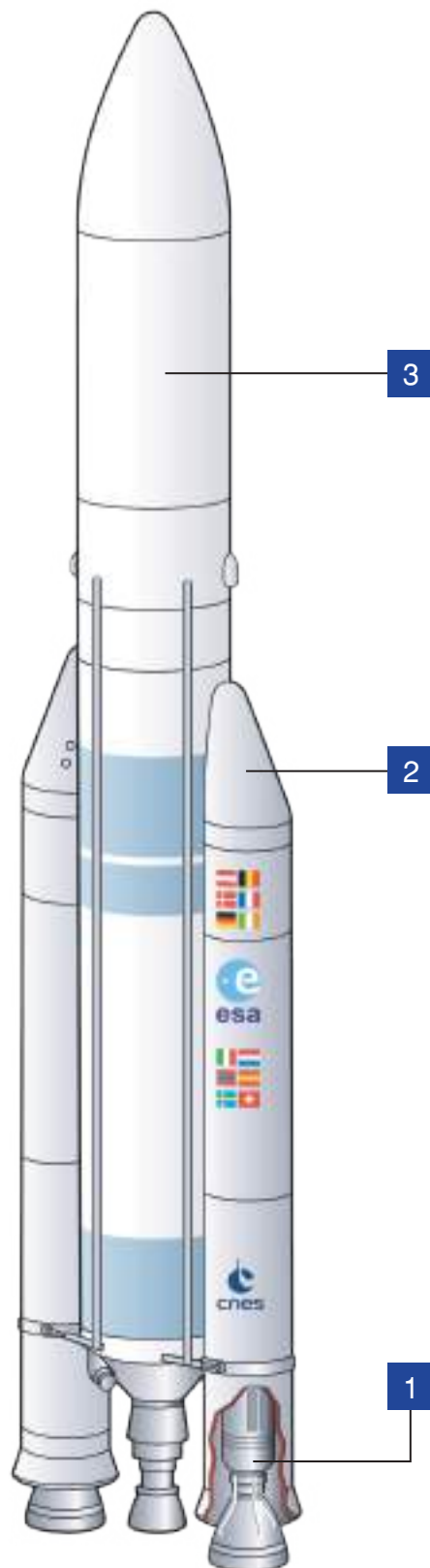

#	Reference	Product Type	Chemical	Colour	Product Properties	Areas of use	Main specifications
<b>SPACE APPLICATIONS</b>							
1	LFPH 006	Heat cured waterborne epoxy phenolic coating	Epoxy Phenolic	Clear varnish, aluminium, gold, black version	Heat resistance and corrosion protection	Heat exchangers, pipes...	
2	PFE 26 39 CF	CF epoxy primer	Epoxy	White	Anticorrosion	Boosters, nozzles	SM78042B
3	VARNISH TD20	Clear varnish	Epoxy	Clear	Insulating varnish	Electronic purposes	Z.12.401



# SOCOMORE WORLDWIDE PRESENCE



## FRANCE

Mäder Aero  
1 Parc d'Activités des Quatre  
Chemins  
BP 24  
95540 MERY-SUR-OISE  
Tel: +33 1 34 64 83 83  
adv-aero@maderaero.fr

### Camp de base

ZI du Prat CS 23707  
Avenue Paul Dupleix  
56037 VANNES Cedex  
Tél: +33 (0)2 97 43 76 90  
Fax: +33 (0)2 97 54 50 27  
socomore@socomore.com

[www.socomore.com](http://www.socomore.com)